

SMERIGLIATRICE ANGOLARE ANGULAR GRINDER

GM62N

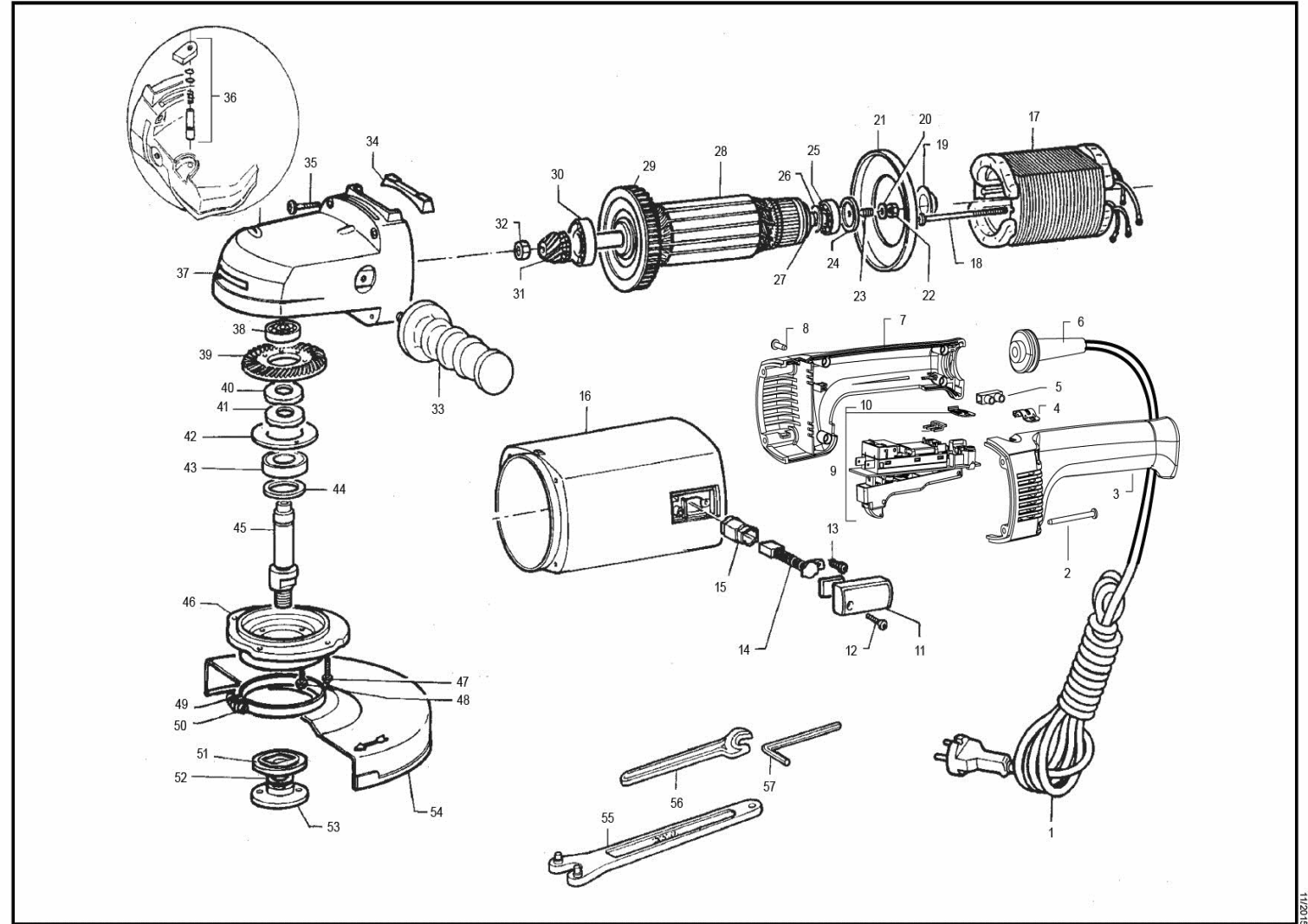

ID	ITEM	DESCRIPTION
001	9C2X4,0N003	CABLE 2x4 (without plug) H 07
001	9C2X6,0N003	CABLE 2x6 (without plug) H 07
002	9.651	SCREW 4,2x50 (8x2") T.C.C.
003	441.239	HALF-HANDLE LEFT
004	442.239	CABLE CLAMP
005	9.1574	NYLON CLAMP 6mm ² (OK434/1 NY LP)
006	421.239	HANDLE GM62 V.72 (D.12,5)
006	422.239	HANDLE GM62 V.48 (D.12,5)
007	44.239	HALF-HANDLE RIGHT
008	9.688	SCREW 4,2x16 T.C.C. (8x5/8)
009	45.00.040	SWITCH 12+
010	451.105	METAL PLATE FOR SWITCH L.T.
011	48.048	BRUSH COVER
012	9.614	SCRE M4 x 12 T.C.C. d7,7 BRN 8.8
013	9.608	SCREW M4 x 6 T.C.C. TROP.+ROND
014	474.038/10	10 BRUSHES BLISTER GM62 BT
015	46.96	BRUSH HOLDER
016	31.092	GM61-GM81 MOTOR BODY
017	2.038/110	STATOR (V.110)
017	2.038/080	STATOR (V.80)
017	2.038/072	STATOR (V.72)
017	2.038/048	STATOR (V.48)
017	2.038/042	STATOR (V.42)
018	9.695	SCREW 2,2x 6,5 (2x1/4") T.C.C.
019	319.092	MOTOR BODY NUT COVER
020	9.349	TOOTHED WASHER
021	73.038	AIR BULKHEAD
022	84.91	NUT M8 GALVANIZE uni 5589
023	9.698	GRAIN 8x14
024	341.40	THRUST WASHER
025	9.17/10	BEARING 629 ZZ-C3
026	9.320	STEEL WASHER d23 x 9,1 s 0,3
027	9.304	STEEL WASHER d15 x 9,1 s 0,1
028	1.092/110	ROTOR (V.110)
028	1.092/072	ROTOR (V. 72)
028	1.092/048	ROTOR (V. 48)
028	1.092/042	ROTOR (V. 42)
029	15.092	FAN 40 BLADES
030	9.36/10	BEARING NSK 6201 T1XZZC3E EA3S6
031	50.137	GEAR SET
032	55.092	NUT FOR NICKEL-PLATED ROTOR
033	81.326	COMPLETE SIDE HANDLE WITHOUT SPANNER
034	65.038	TOOL SUPPORT
035	9.575	SCREW 4,8x50 (10x2") T.C.C. BURNISHED
036	323.137/C	COMPLETE UNLOCK SPRING BUTTON
037	32.137	GEAR BOX
038	9.27/10	BEARING 6001 ZZ-C3
039	50.137	GEAR SET
040	541.40	SPACER d 22 x 15,2 s 1
041	9.309	STEEL WASHER d22 x 15,2 s 0,3
042	351.038	BEARING LOCKING FLANGE
043	9.26/10	BEARING 6202 ZZ-C3
044	333.038	d 28x15 s 0,3 STEEL WASHER
045	51.092	SPINDLE SHAFT
046	33.038	FLANGE
047	9.689	SCREW M5 x 14 T.C.C. 8G BURNISHED

ID	ITEM	DESCRIPTION
048	9.637	SCREW M4 x 16 T.C.C. 8G BURNISHED
049	9.527	NUT M6
050	9.678	SCREW M6 x 25 T.B.E. 12K BURNISHED
051	936.092	SUPPORT WHEEL NUT
052	9.243	STEEL WASHER d42 x 22,5 s 0,4
053	934.092	LOCKING WHEEL NUT
054	822.49	PROTECTION
055	836.24	SPANNER
056	83.13	SPANNER mm 17
057	9.1395	ALLEN SPANNER 5mm